

Linear Wire Antennas

EE-4382/5306 - Antenna Engineering

Outline

- Introduction
- Infinitesimal Dipole
- Small Dipole
- Finite Length Dipole
- Half-Wave Dipole
- Ground Effect

Constantine A. Balanis, *Antenna Theory: Analysis and Design* 4th Ed., Wiley, 2016.
Stutzman, Thiele, *Antenna Theory and Design* 3rd Ed., Wiley, 2012.

Finite Length Dipole

Finite length dipole

A finite length dipole is still in the order of $a \ll \lambda$, where a is the thickness of the. However, the length l of the antenna is in the same order of magnitude as the operating wavelength $\frac{\lambda}{10} < l \leq 2\lambda$

The current distribution is now approximated to a sinusoidal function:

$$\mathbf{I}_e(x, y, z) = \begin{cases} \hat{\mathbf{a}}_z I_0 \sin\left(k\left[\frac{l}{2} - z\right]\right), & 0 \leq z \leq \frac{l}{2} \\ \hat{\mathbf{a}}_z I_0 \sin\left(k\left[\frac{l}{2} - z\right]\right), & -\frac{l}{2} \leq z \leq 0 \end{cases}$$

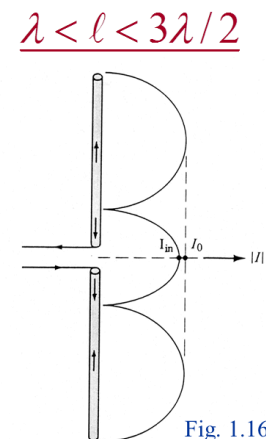
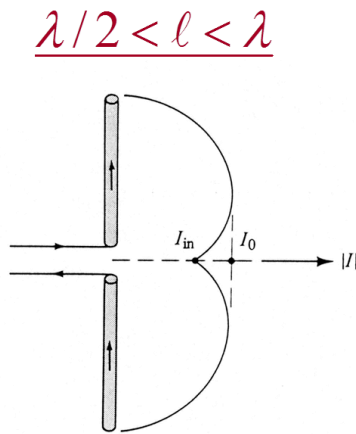
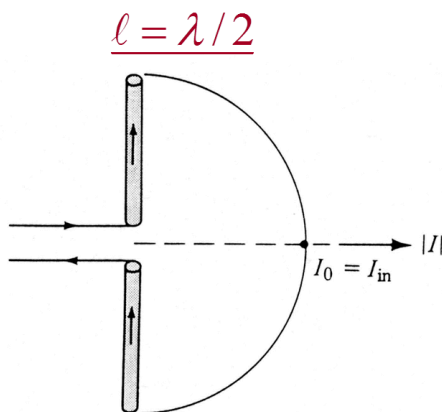

Current Distributions Along the Length of a Linear Wire Antenna

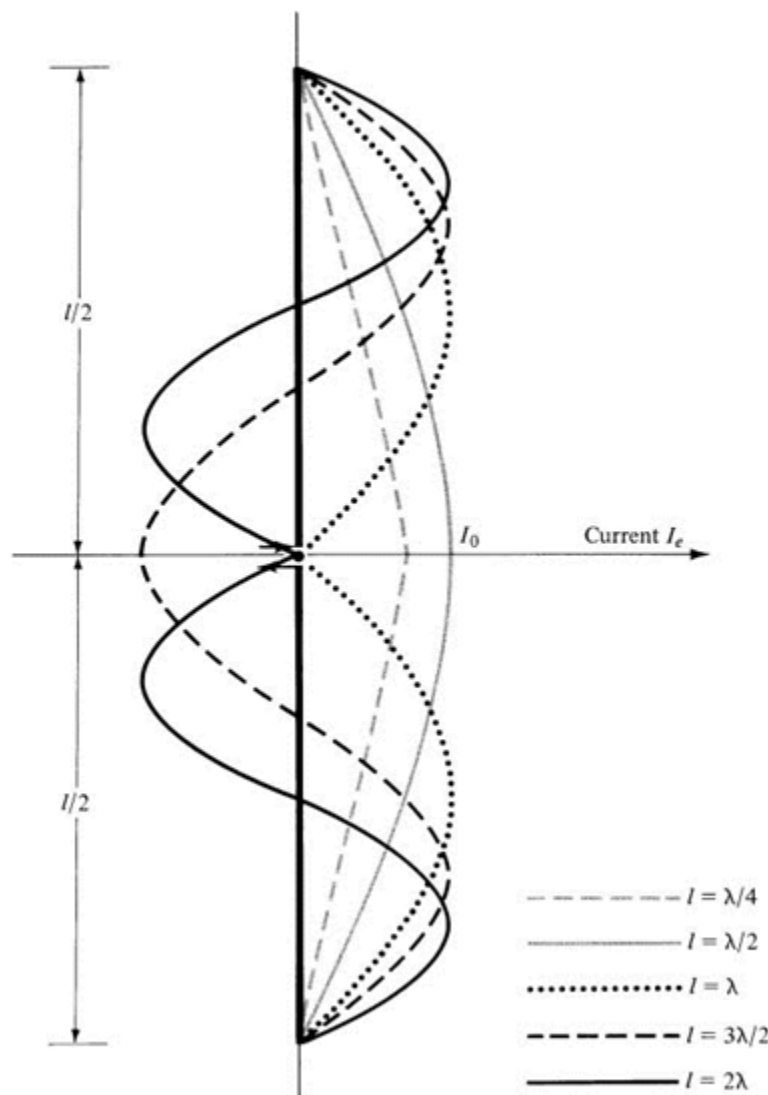

Fig. 4.8

Finite Dipole Geometry & Far-Field Approximations

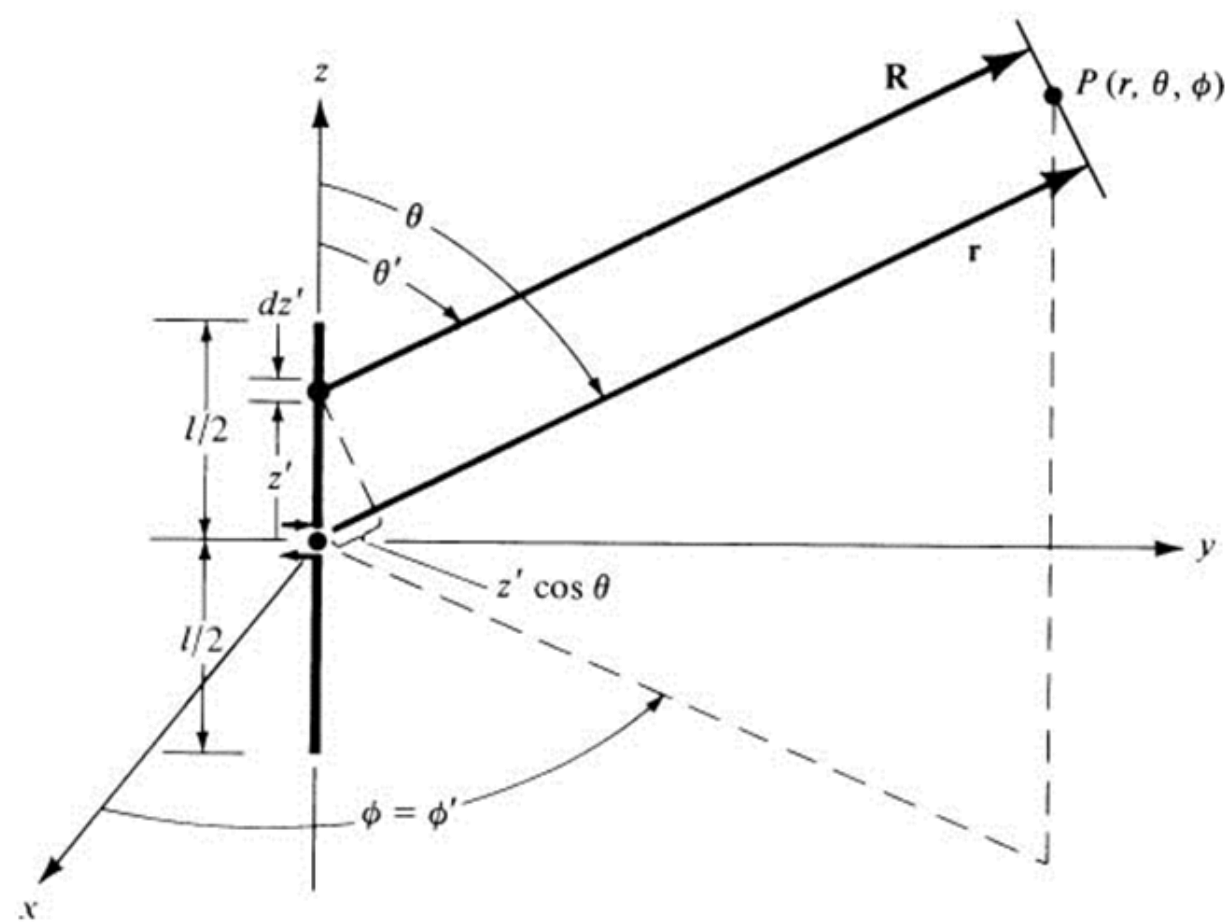
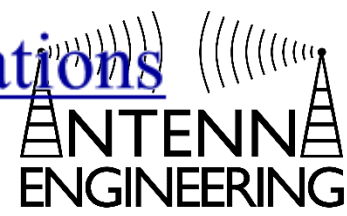
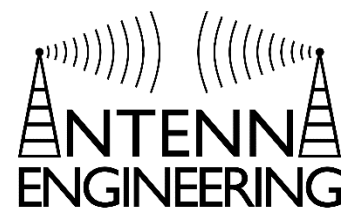

Fig. 4.5b

Copyright©2016 by Constantine A. Balanis
All rights reserved

Chapter 4
Linear Wire Antennas

Radiated Fields: Element Factor, Space Factor, and Multiplication



To obtain the radiated fields of the finite length dipole in the far-field region, we subdivide the antenna into infinitesimal dipoles and integrate to obtain the contributions from all the infinitesimal elements.

$$dE_{\theta} = j\eta \frac{kI_e(x, y, z)e^{-jkR}}{4\pi R} \sin(\theta) dz$$

$R \cong r - z \cos(\theta)$ for far-field approximations in phase terms

$R \cong r$ for far-field approximations in amplitude terms

$$dE_{\theta} = j\eta \frac{kI_e(x, y, z)e^{-jkr}}{4\pi r} \sin(\theta) e^{+jkz \cos(\theta)} dz$$

$$E_{\theta} = \iint_{-\frac{l}{2}}^{+\frac{l}{2}} dE_{\theta} = \int_{-\frac{l}{2}}^{+\frac{l}{2}} j\eta \frac{ke^{-jkr}}{4\pi r} \sin(\theta) \left[\int_{-\frac{l}{2}}^{+\frac{l}{2}} I_e(x, y, z)e^{+jkz \cos(\theta)} dz \right]$$

total field = (element factor) \times (space factor)

Radiated Fields – Far-Field

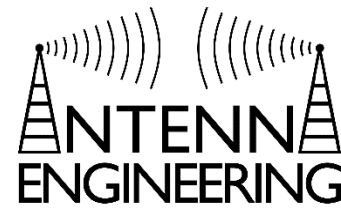

$$E_{\theta} = j\eta \frac{I_0 e^{-jkr}}{2\pi r} \left[\frac{\cos\left(\frac{kl}{2} \cos(\theta)\right) - \cos\left(\frac{kl}{2}\right)}{\sin(\theta)} \right]$$

$$H_{\phi} = \frac{E_{\theta}}{\eta} = j \frac{I_0 e^{-jkr}}{2\pi r} \left[\frac{\cos\left(\frac{kl}{2} \cos(\theta)\right) - \cos\left(\frac{kl}{2}\right)}{\sin(\theta)} \right]$$

HPBW

1. $l \leq \frac{\lambda}{50}$: HPBW = 90°
2. $l \leq \frac{\lambda}{2}$: HPBW = 74.93°
3. $l \leq \lambda$: HPBW = 47.8°

$$\frac{\lambda}{50} \leq l \leq \lambda$$

$$90^\circ \geq \text{HPBW} \geq 47.8^\circ$$

$$\Delta(\text{HPBW}) = 42.2^\circ$$

Fig. 4.6

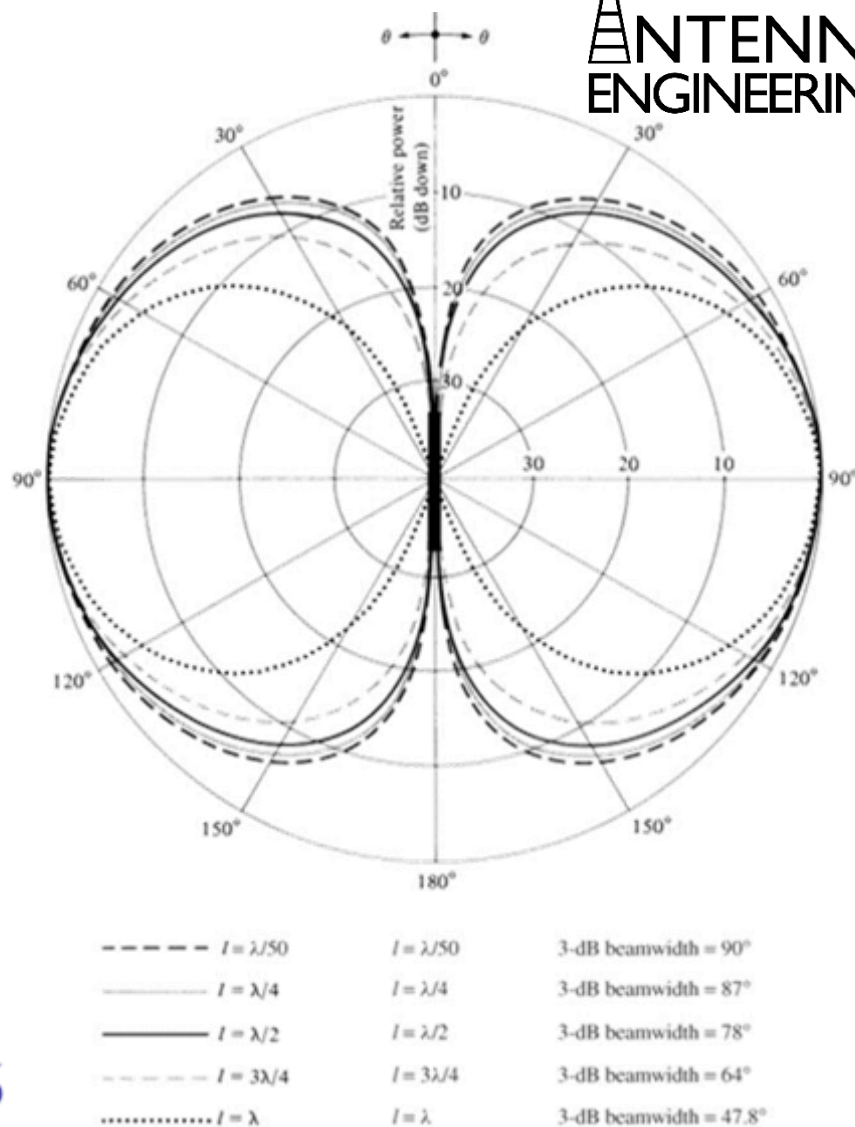

Chapter 4

Linear Wire Antennas

Copyright©2016 by Constantine A. Balanis
All rights reserved

Power Density, Radiation Intensity, Radiation Resistance, Directivity

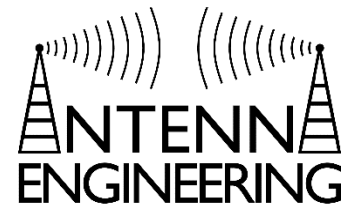

$$W_{av} = \frac{1}{2} \operatorname{Re}[\mathbf{E} \times \mathbf{H}^*] = \frac{1}{2} \operatorname{Re} \left[\hat{\mathbf{a}}_{\theta} E_{\theta} \times \hat{\mathbf{a}}_{\phi} \frac{E_{\phi}^*}{\eta} \right]$$

$$P_{rad} = \oiint_S \mathbf{W}_{av} \cdot d\mathbf{s} = \int_0^{2\pi} \int_0^{\pi} \hat{\mathbf{a}}_r W_{av} \cdot \hat{\mathbf{a}}_r r^2 \sin \theta d\theta d\phi$$

$$P_{rad} = \eta \frac{|I_0|^2}{4\pi} \left\{ C + \ln(kl) - C_i(kl) + \frac{1}{2} \sin(kl) [S_i(2kl) - 2S_i(kl)] + \frac{1}{2} \cos(kl) \left[C + \ln\left(\frac{kl}{2}\right) + C_i(2kl) - 2C_i(kl) \right] \right\}$$

$$C_i(x) = - \int_x^{\infty} \frac{\cos y}{y} dy = \int_{\infty}^x \frac{\cos y}{y} dy$$

$$S_i(x) = \int_0^x \frac{\sin y}{y} dy$$

Power Density, Radiation Intensity, Radiation Resistance, Directivity

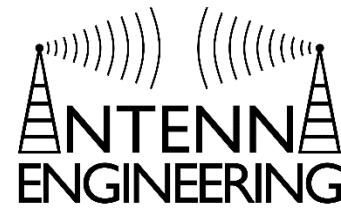

$$R_r = \frac{2P_{rad}}{|I_0|^2} = \frac{\eta}{2\pi} \left\{ \begin{aligned} &C + \ln(kl) - C_i(kl) + \frac{1}{2} \sin(kl)[S_i(2kl) - 2S_i(kl)] + \\ &\frac{1}{2} \cos(kl) \left[C + \ln\left(\frac{kl}{2}\right) + C_i(2kl) - 2C_i(kl) \right] \end{aligned} \right\}$$

$$D_0 = \frac{2F_0|_{max}}{Q}$$

$$Q = \left\{ \begin{aligned} &C + \ln(kl) - C_i(kl) + \frac{1}{2} \sin(kl)[S_i(2kl) - 2S_i(kl)] + \\ &\frac{1}{2} \cos(kl) \left[C + \ln\left(\frac{kl}{2}\right) + C_i(2kl) - 2C_i(kl) \right] \end{aligned} \right\}$$

Input Resistance

To calculate Input Resistance at the terminals, assume lossless antenna (no R_L) and equate the power at the input to the power at the current maximum

$$\frac{|I_{in}|^2}{2} R_{in} = \frac{|I_0|^2}{2} R_r$$

$$R_{in} = \left[\frac{I_0}{I_{in}} \right]^2 R_r$$

R_{in} = Radiation Resistance at Input terminals

R_r = Radiation Resistance at Current Maximum

I_0 = Current Maximum

I_{in} = Current at input terminals

Assuming a sinusoidal current,

$$R_{in} = \frac{R_r}{\sin^2\left(\frac{kl}{2}\right)}$$

Directivity And Radiation/Input Resistance

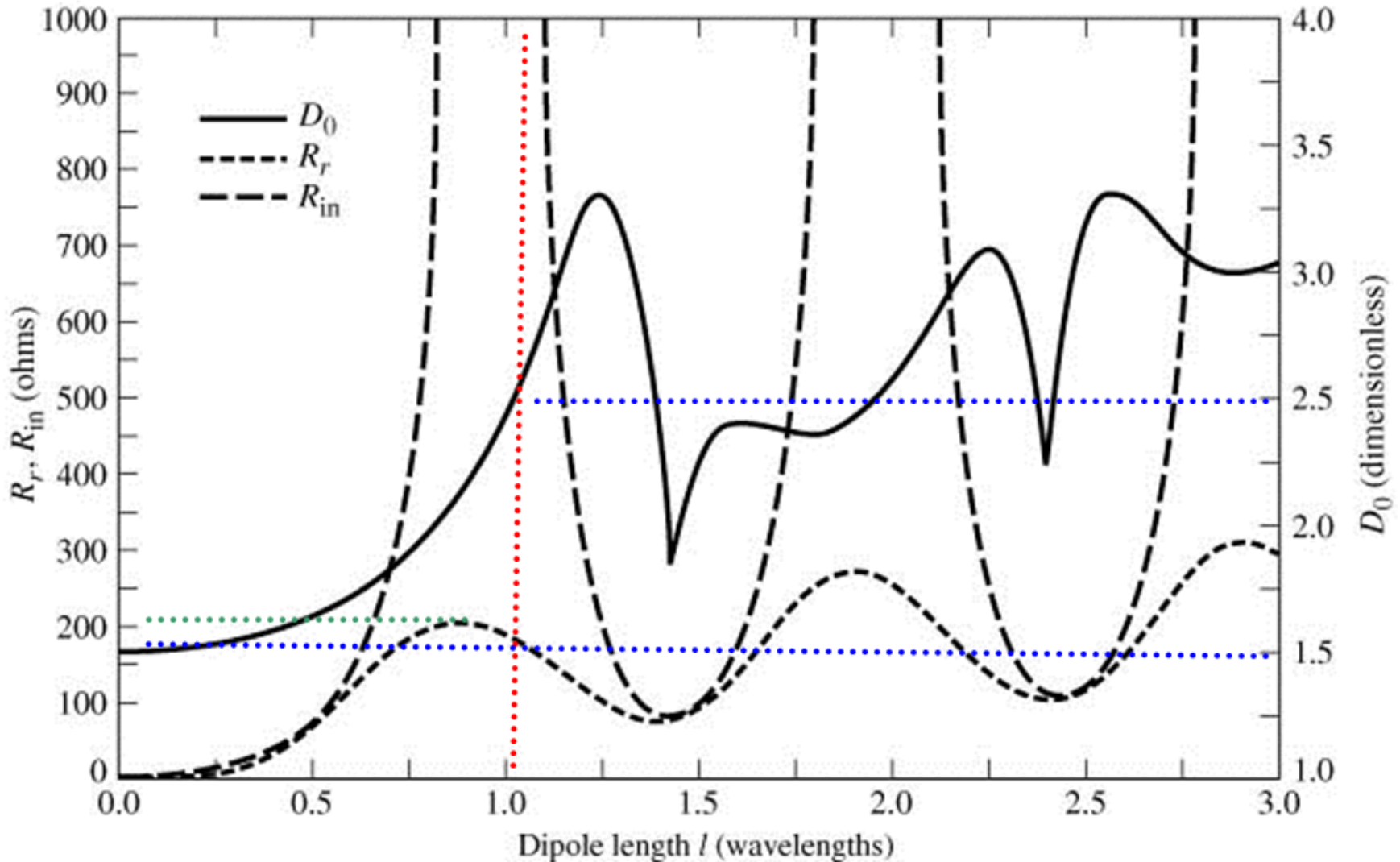
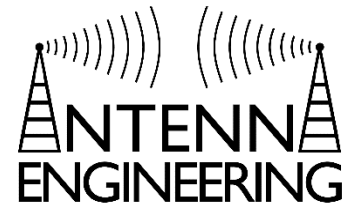

Reactance (Referred to the Current Maximum) of Linear Dipole with Sinusoidal Current Distribution for Different Wire Radii

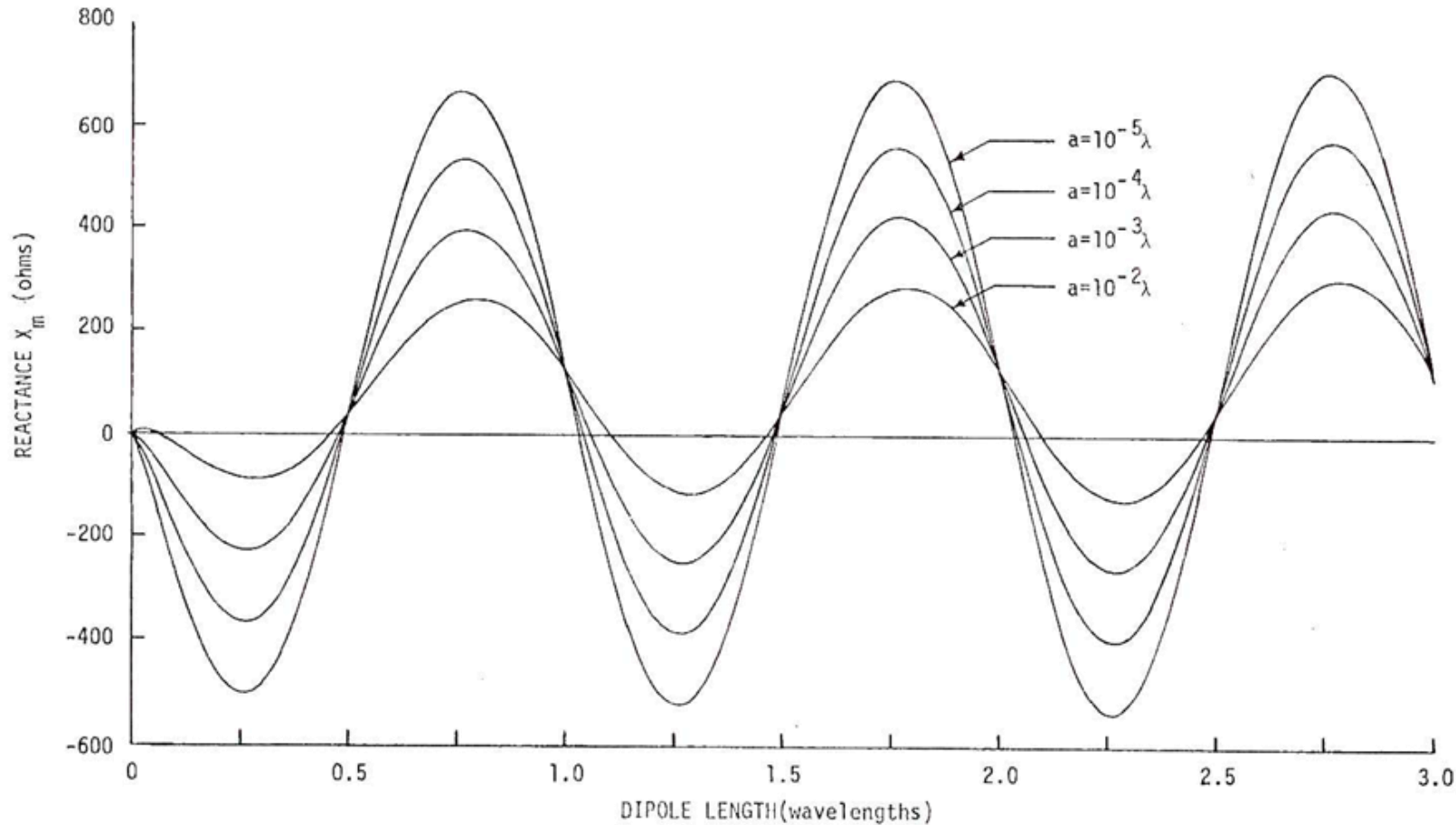

Copyright©2016 by Constantine A. Balanis
All rights reserved

Fig. 4.9(b)

Chapter 4
Linear Wire Antennas

Half-Wave Dipole

Half-Wave Dipole

One of the most commonly used antennas.

The arms are $\frac{\lambda}{4}$ in length and are fed at the center.

Radiation Resistance is excellent for transmission line connections:

$$R_r = 73$$
$$Z_{in} = 73 + j42.5$$

To get rid of reactance, it is common practice to cut the length until it vanishes.

Directivity is also good for omnidirectional terrestrial communications

$$D_0 = \frac{4\pi U_{max}}{P_{rad}} = 1.643 = 2.156 \text{ dBi}$$

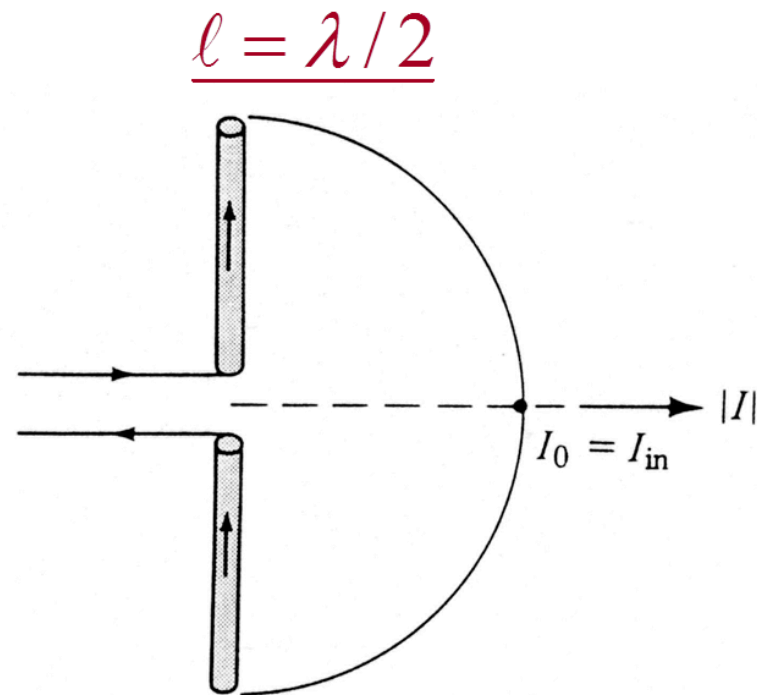

Copyright © 2016 by Constantine A. Balanis
All right reserved

Fig. 1.16b

Chapter 1
Antennas

Half-Wave Dipole Fields

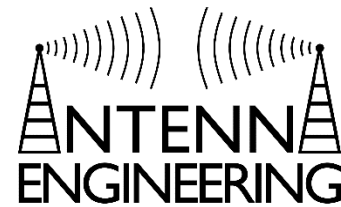

$$E_{\theta} \cong j\eta \frac{I_0 e^{-jkr}}{2\pi r} \left[\frac{\cos\left(\frac{\pi}{2} \cos(\theta)\right)}{\sin(\theta)} \right]$$

$$H_{\phi} \cong j \frac{I_0 e^{-jkr}}{2\pi r} \left[\frac{\cos\left(\frac{\pi}{2} \cos(\theta)\right)}{\sin(\theta)} \right]$$

$$W_{av} \cong \eta \frac{|I_0|^2}{8\pi^2 r^2} \sin^3(\theta)$$

$$U = r^2 W_{rad} \cong \eta \frac{|I_0|^2}{8\pi^2} \sin^3(\theta)$$

Normalized Power Pattern

$$U_n \cong \sin^3(\theta)$$

Half-Wave Dipole

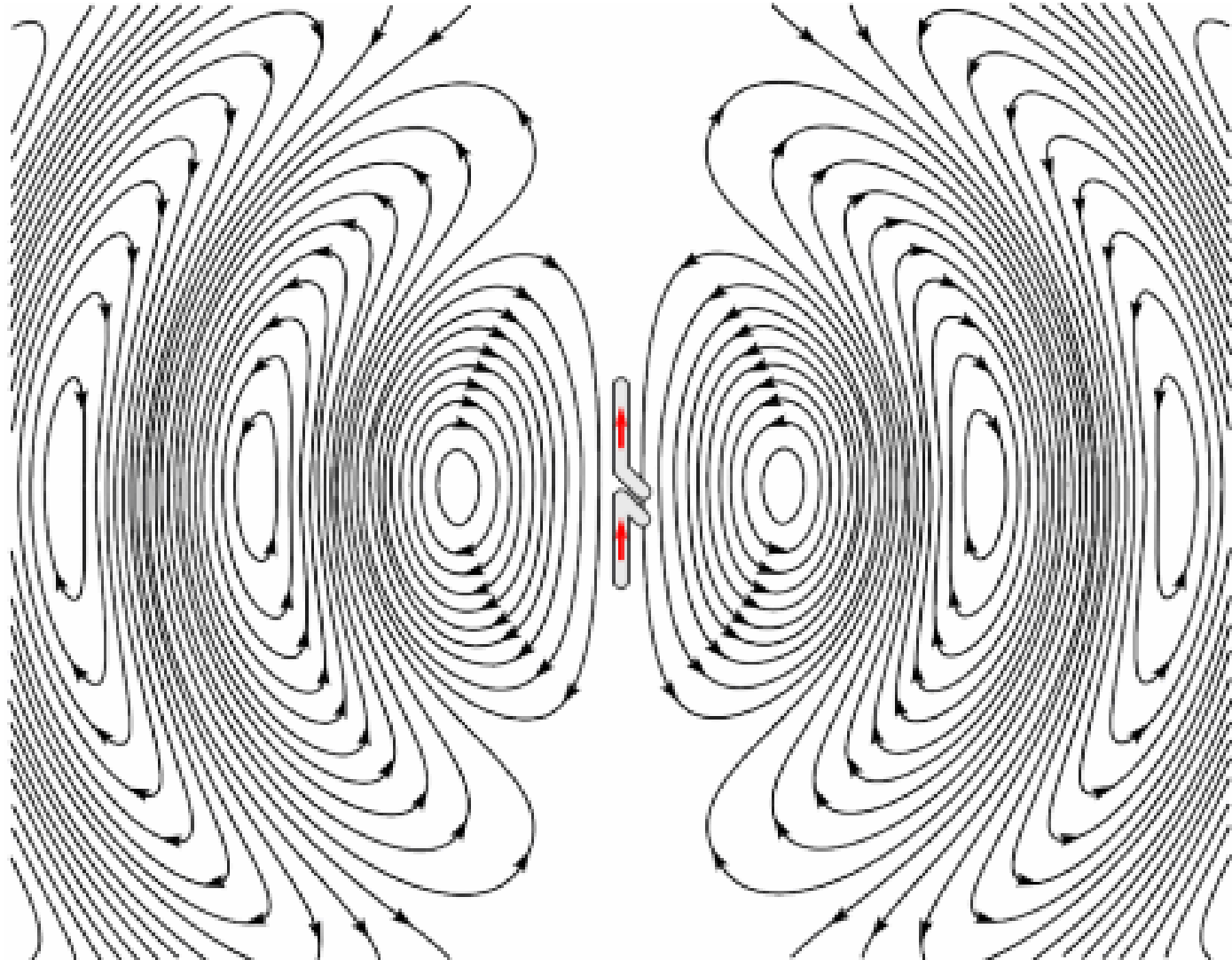

Half-Wave Dipole

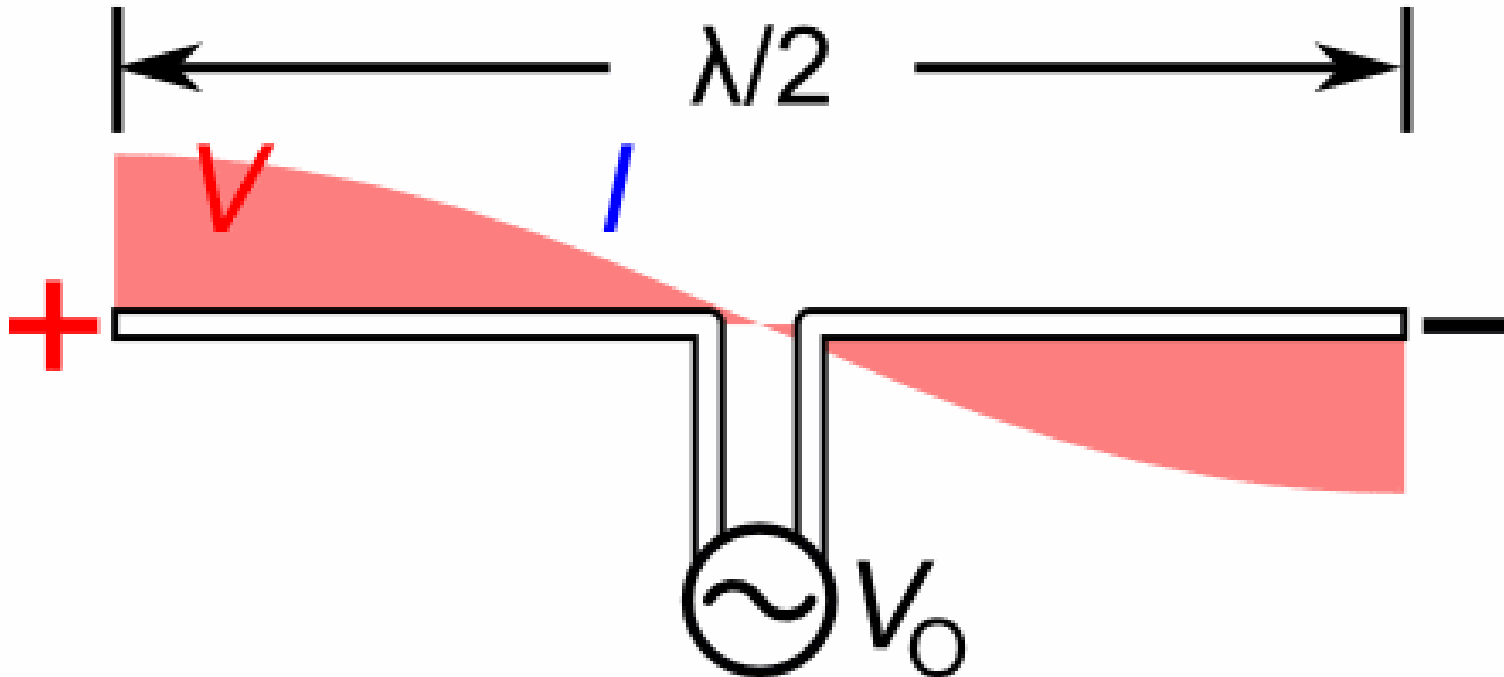

Half-Wave Dipole

Three-Dimensional Pattern of $\lambda/2$ Dipole

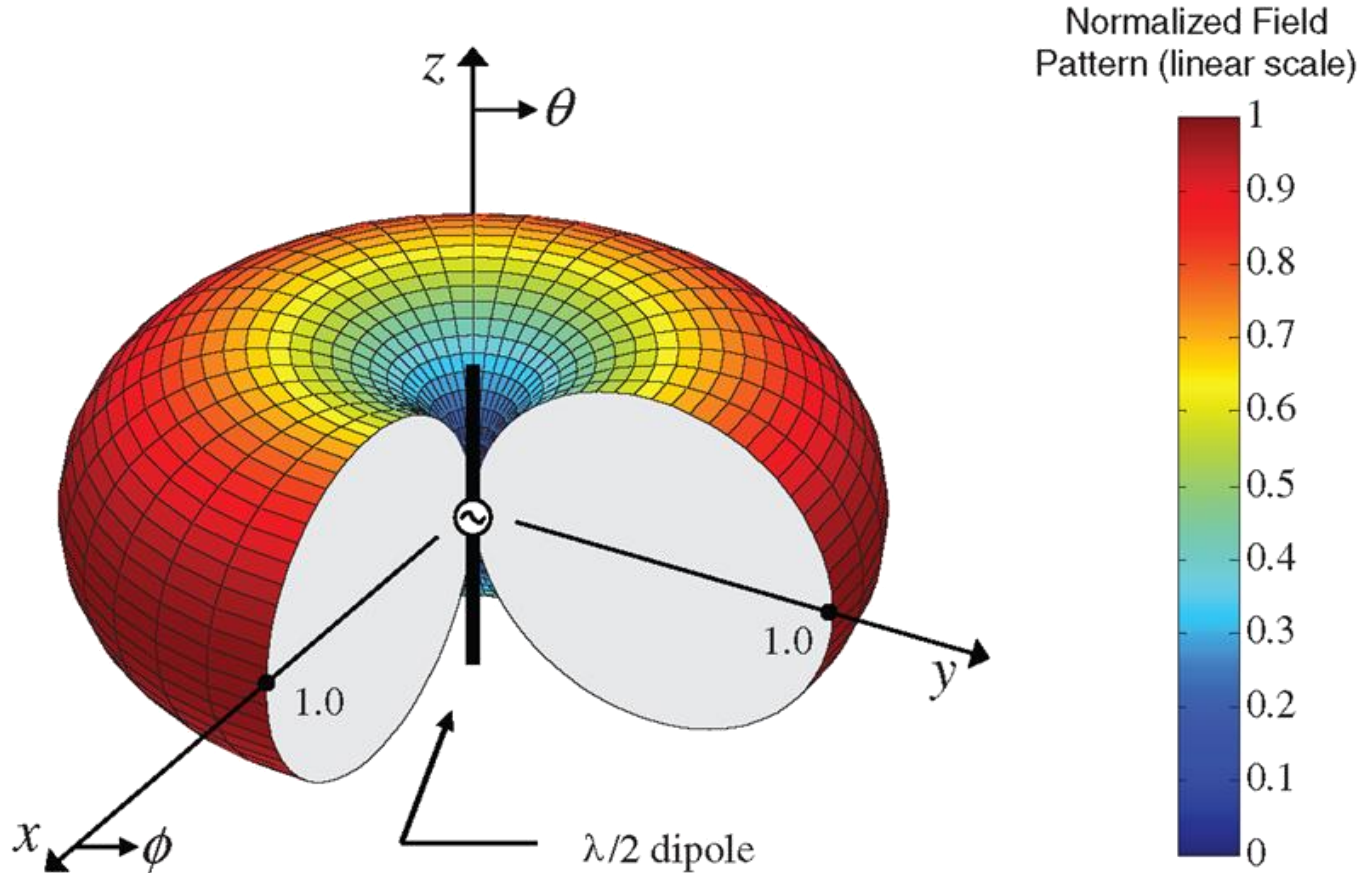

Half-Wave Dipole

Half-Wavelength Dipole Approximations

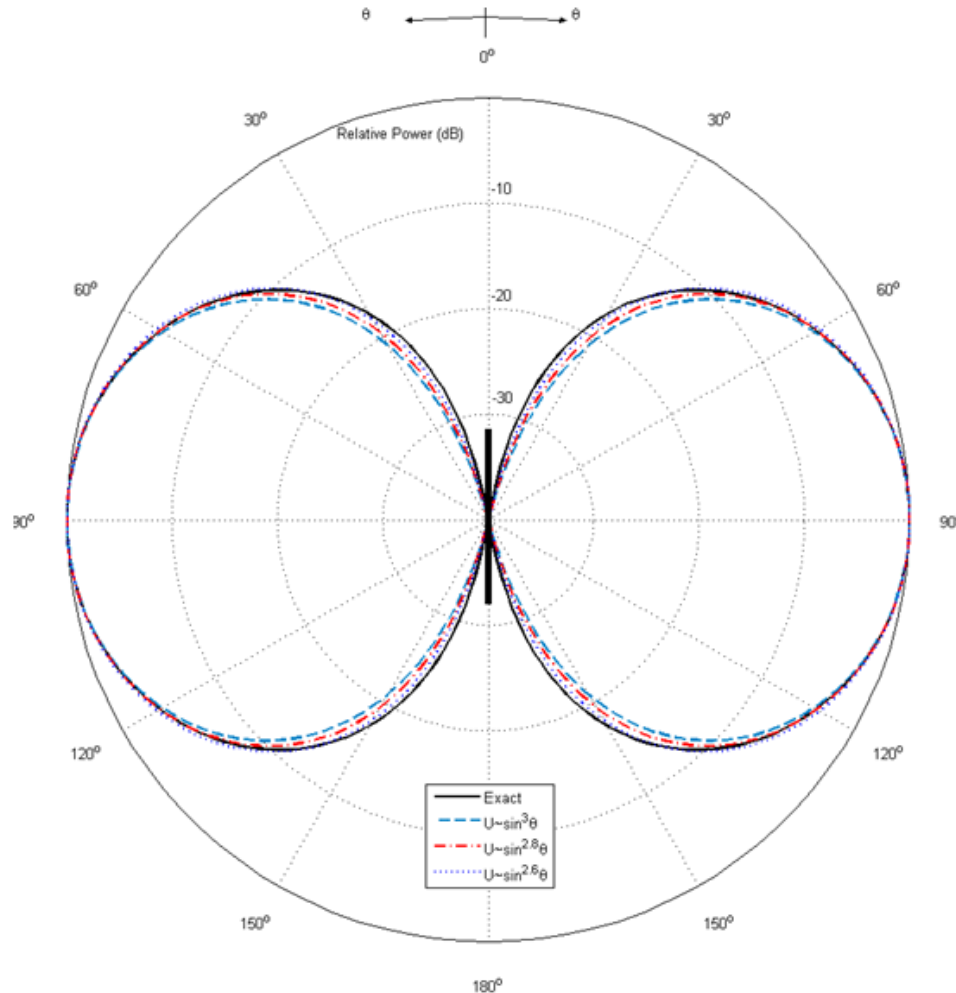

Copyright©2016 by Constantine A. Balanis
All rights reserved

Fig. 4.12(b)

Chapter 4
Linear Wire Antennas

Dipole - Examples

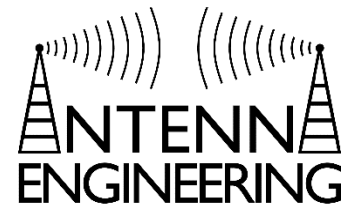

A center-fed dipole of length l is attached to a balanced lossless transmission line whose characteristic impedance is 50Ω . Assuming the dipole is resonant at the given length, find the input VSWR when

(a) $l = \frac{\lambda}{4}$

(b) $l = \frac{\lambda}{2}$

(c) $l = \frac{3\lambda}{4}$

(d) $l = \lambda$

$$VSWR = \frac{1 + |\Gamma|}{1 - |\Gamma|}$$

$$\Gamma = \frac{R_{in} - Z_0}{R_{in} + Z_0}$$

$$R_{in} = \frac{R_r}{\sin^2\left(\frac{kl}{2}\right)}$$

$$R_r \Big|_{l=\frac{\lambda}{4}} \cong 6.84$$

$$R_r \Big|_{l=\frac{\lambda}{2}} \cong 73$$

$$R_r \Big|_{l=\frac{3\lambda}{4}} \cong 372$$

$$R_r \Big|_{l=\lambda} = \infty$$

Dipole - Examples

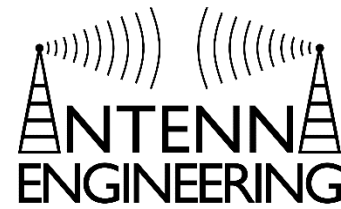

The approximate far zone electric field radiated by a very thin wire linear dipole of length l , positioned symmetrically along the z-axis, is given by

$$E_{\theta} = C_o \sin^{1.5}(\theta) \frac{e^{-jkr}}{r}$$

Where C_o is a constant. Determine the exact directivity and the length of the dipole

$$D_0 = \frac{4\pi U_{max}}{P_{rad}} \qquad P_{rad} = \int_0^{2\pi} \int_0^{\pi} U \sin(\theta) d\theta d\phi$$

Dipole Examples

A $\frac{\lambda}{2}$ dipole with its center at the origin radiates a time-averaged power of 600 W. A second $\frac{\lambda}{2}$ dipole is placed with its center point at $P(r, \theta, \phi)$ where $r = 200$ m, $\theta = 90^\circ$, $\phi = 40^\circ$. It is oriented so that its axis is parallel to that of the transmitting antenna. What is the available power at the terminals of the second (receiving) dipole? Assume both antennas are lossless and perfectly matched in all unmentioned parameters.

Friis Transmission Equation

$$P_r = P_t \left(\frac{\lambda}{4\pi r} \right)^2 D_{0t} D_{0r}$$

$$U \cong \sin^3(\theta)$$